



Larson Electronics LLC www.LarsonElectronics.com sales@larsonelectronics.com
9419 E US HWY 175, Kemp, TX 75143 - P: (800) 369-6671 - F: (903) 498-3364

EPSLED-80-141

IMPORTANT: Before installing, check the carton label and fixture nameplate to be sure you have the correct LED color and type of fixture. Read all instructions before proceeding.

WARNING: Deactivate circuit before beginning installation.

NOTE: All installations must comply with applicable local and/or National Electrical Code.

INSTALLATION

1. Using the component drawing, remove the splice box from the fixture (if attached).
2. Refer to the splice box mount instruction sheet K1087 included with the splice box. Install the pendant mount splice box to the conduit and secure with locking set screw. Install the ceiling mount using four (4) external mounting screws.
NOTE: Fixture splice box must be grounded.
3. Remove the terminal block from the splice box by loosening the two (2) mounting screws.
4. Connect the ground wire to the green screw inside the base of the splice box.
5. Connect the supply lines to the terminal block. (Note: For DC voltage the terminal block is to be wired "POS" (+) to the "LINE" terminal and "NEG" (-) to the "COM" or "WHITE" terminal.)
6. Reinstall the terminal block in the splice box, and securely tighten it in place.
7. Thread the fixture into the splice box and secure with the set screw. Be sure that the mating threads are clean and adequately lubricated.
8. Check the tightness of all set screws and all threaded joints. Turn on the supplying circuit to test the fixture.

OPERATIONAL DATA

Operate this fixture at its rated voltage. See fixture nameplate for this data.

Caution: Disconnect the supplying circuit before opening or reprogramming this fixture.

REPROGRAM FLASH RATE

1. Loosen the set screw, unscrew and remove the globe support assembly.
2. Locate the DIP switch on the LED power supply at the top center of the LED heatsink.
CAUTION: Use care not to disturb the LED wire harness. Change the DIP switch pin settings as per the diagram.
3. Inspect the mating threads to be sure they are clean and well lubricated. Inspect the globe for scratches.
NOTE: If the globe is scratched or chipped, the globe support assembly must be replaced.
4. Reinstall the globe assembly.



Larson Electronics LLC www.LarsonElectronics.com sales@larsonelectronics.com
9419 E US HWY 175, Kemp, TX 75143 - P: (800) 369-6671 - F: (903) 498-3364

5. When reprogramming, be careful not to damage the external threaded areas, since they maintain the fixtures explosion-proof properties. The threads should be lubricated periodically.
6. Check the tightness of all set screws and all threaded joints. Turn on the supplying circuit to test the fixture.

MAINTENANCE DATA

To maintain maximum light output from this fixture, it should be cleaned periodically per the following suggestions.

- The aluminum exterior of the fixture should be cleaned only with a mild soap or cleaner, and should be rinsed with water immediately. Alkaline or acidic cleaners should never be used on aluminum.
- The glass globe may be cleaned with any non-abrasive cleaner. The globe should be regularly inspected for scratches and chips.
- These periodic cleaning procedures are important in preventing the accumulation of dust and dirt which will impair the light output of the fixture.



Larson Electronics LLC www.LarsonElectronics.com sales@larsonelectronics.com
9419 E US HWY 175, Kemp, TX 75143 - P: (800) 369-6671 - F: (903) 498-3364

FLASH RATE PROGRAMMING

STEADY - FACTORY SETTING

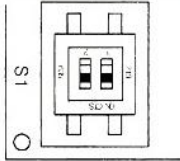

DIP PINS
BOTH
DOWN

SINGLE FLASH

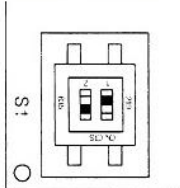

DIP PINS
LEFT-DOWN
RIGHT-UP

DOUBLE FLASH

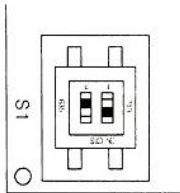

DIP PINS
LEFT-UP
RIGHT-DOWN

OFF

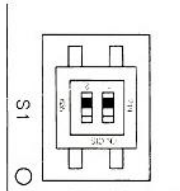

DIP PINS
BOTH-UP

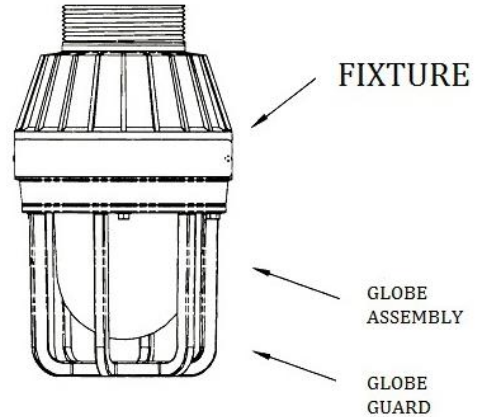
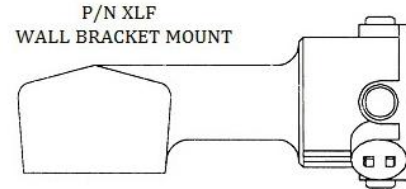
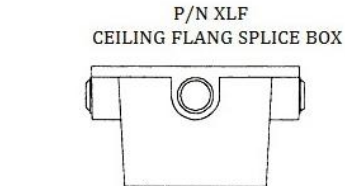
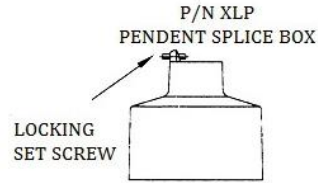

COMPONENT DRAWING