

8 7 6 5 4 3 2 1

D
C
B
A

D
C
B
A

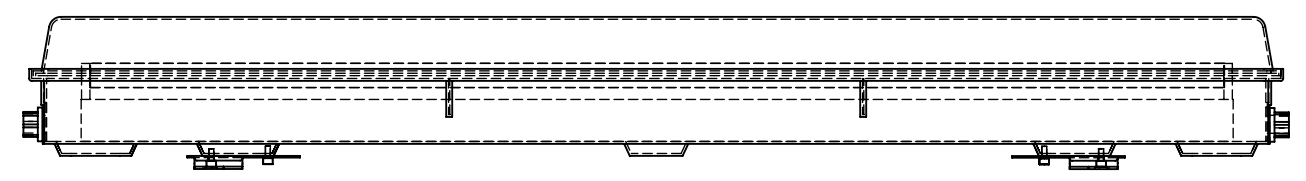
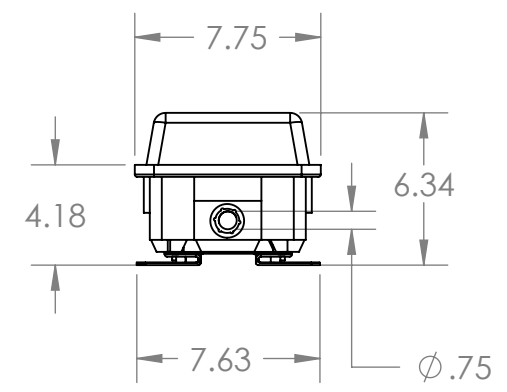
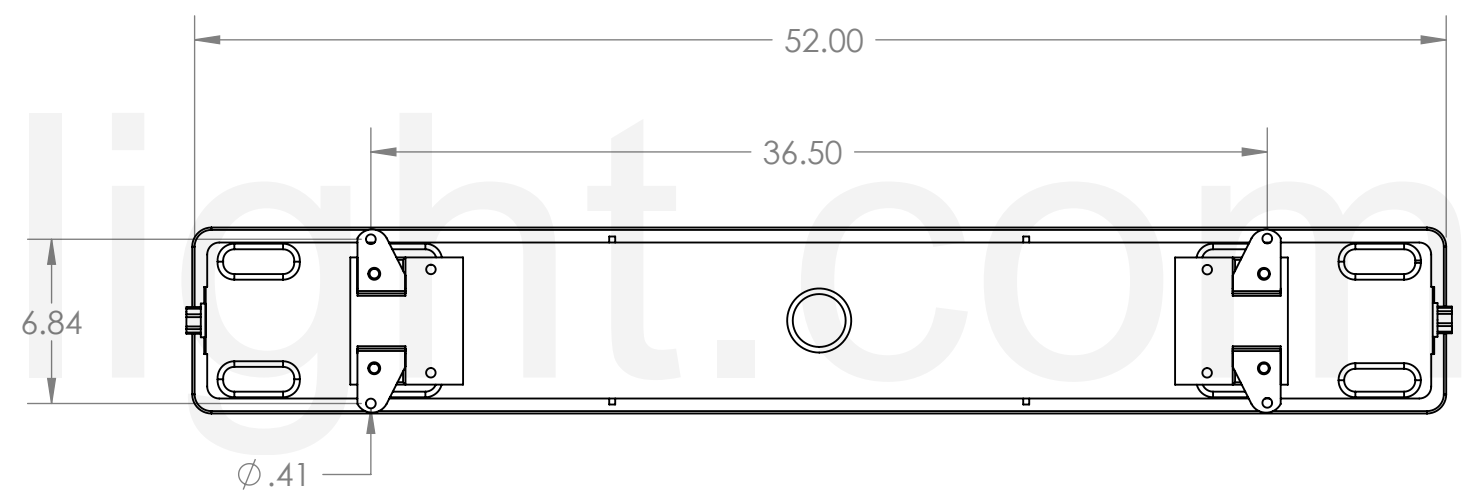
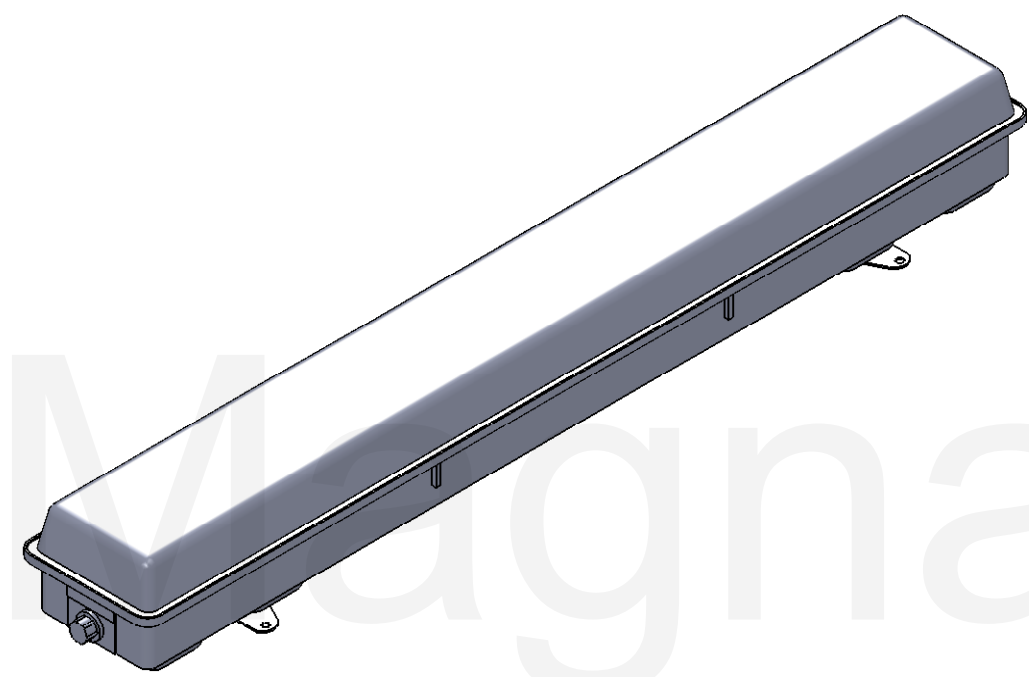

PROPRIETARY AND CONFIDENTIAL
 THE INFORMATION CONTAINED IN THIS DRAWING IS THE SOLE PROPERTY OF Magnalight.com. ANY REPRODUCTION IN PART OR AS A WHOLE WITHOUT THE WRITTEN PERMISSION IS PROHIBITED.

		UNLESS OTHERWISE SPECIFIED:		NAME	DATE	Magnalight.com	
		DIMENSIONS ARE IN INCHES		DRAWN		TITLE:	
		TOLERANCES:		CHECKED		HALP-48-2L	
		FRACTIONAL ±		ENG APPR.		SIZE	DWG. NO.
		ANGULAR: MACH ± BEND ±		MFG APPR.		B	HALP-48-2L
		TWO PLACE DECIMAL ±		Q.A.		SCALE: 1:8	WEIGHT:
		THREE PLACE DECIMAL ±		COMMENTS:		SHEET 1 OF 1	
		INTERPRET GEOMETRIC TOLERANCING PER:					
		MATERIAL					
NEXT ASSY	USED ON	FINISH					
APPLICATION		DO NOT SCALE DRAWING					
						REV	A

8 7 6 5 4 3 2 1