

8 7 6 5 4 3 2 1

D
C
B
A

D
C
B
A

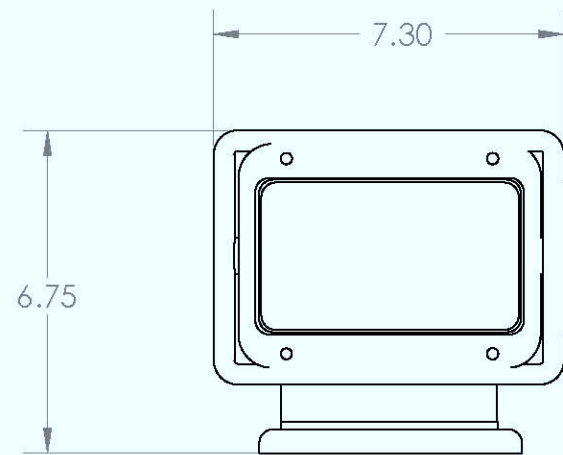
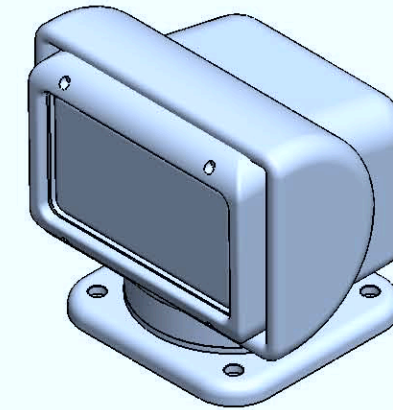
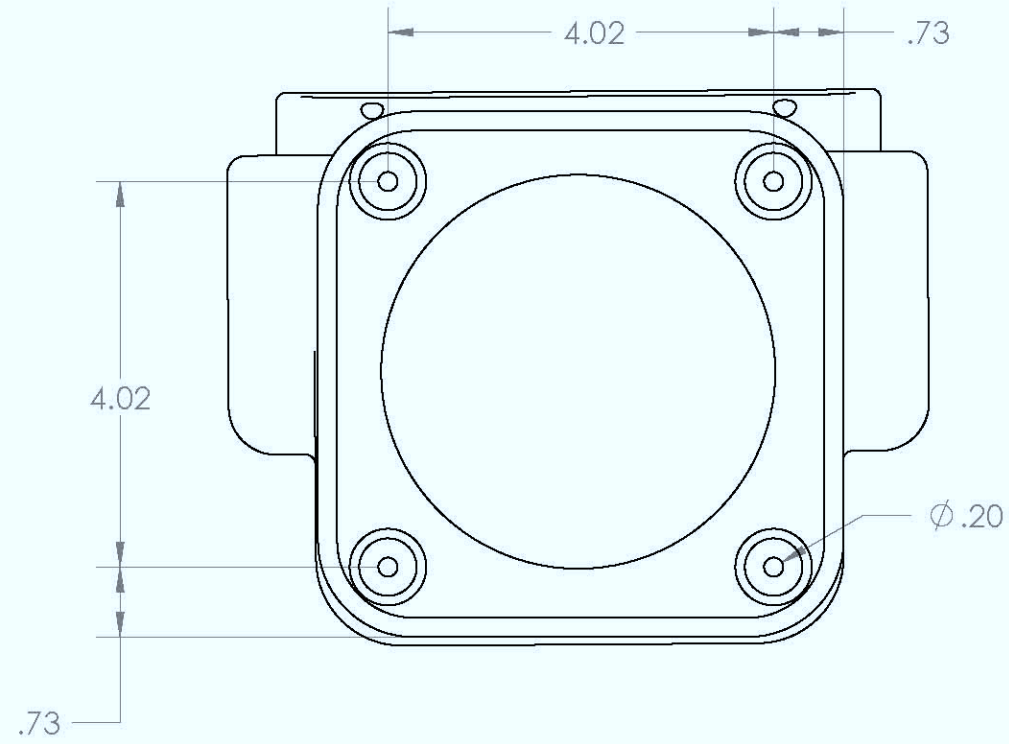
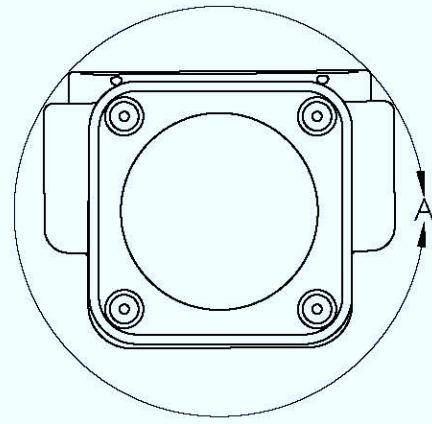

DETAIL A
SCALE 1 : 2

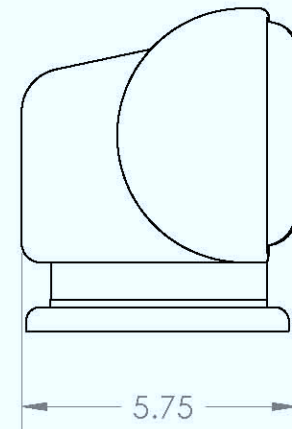

PROPRIETARY AND CONFIDENTIAL
THE INFORMATION CONTAINED IN THIS DRAWING IS THE SOLE PROPERTY OF Magnalight.com. ANY REPRODUCTION IN PART OR AS A WHOLE WITHOUT THE WRITTEN PERMISSION OF Magnalight.com IS PROHIBITED.

		UNLESS OTHERWISE SPECIFIED:		NAME	DATE	Magnalight.com	
		DIMENSIONS ARE IN INCHES		DRAWN	6/09	TITLE:	
		TOLERANCES:		CHECKED		Radio Ray	
		FRACTIONAL ±		ENG APPR.		SIZE	
		ANGULAR: MACH ± BEND ±		MFG APPR.		DWG. NO.	
		TWO PLACE DECIMAL ±		Q.A.		GL-2XXX Radoray	
		THREE PLACE DECIMAL ±		COMMENTS:		REV	
		INTERPRET GEOMETRIC TOLERANCING PER:				A	
		MATERIAL				SCALE: 1:4	
		FINISH				WEIGHT:	
NEXT ASSY	USED ON	DO NOT SCALE DRAWING				SHEET 1 OF 1	
APPLICATION							

8 7 6 5 4 3 2 1